



Automatic error correction

Every gram of material is automatically adjusted towards perfect dispense rates.

Wide range of settings

Each material is dosed by a stainless steel slide gate. The slide gate is capable of dosing a wide range of settings, from as little as 1% to 100%, based on an average density free flowing material (0.65).

Slide gate restrictor

For low percentage settings (1% - 4%) a slide gate restrictor (SGR-1) is recommended to restrict the opening of the gate by 50%. This reduces flow and enhances control.

WSB 900 Series

The WSB 950 consists of 1 hopper with 5 material compartments. Designed for large extruders, blown film lines and central blending systems with throughputs up to 2,660 lb/hr (1,200 kg/hr).

Batch size

The hoppers are mounted above the weigh bin with a default 19.8 lb (9 kg) batch size.

High consistent accuracy

On every material within $\pm 0.1\%$ on a 1% setting.

Sequential dispensing

The system tares the weight of the weigh bin and then each material is dispensed – Regrind, Natural, Color and Additive – in sequence to ensure accurate dispenses of every material within the blend.

Homogenous mix

A complete batch is released into the mixing chamber and mixed with the previous batch to ensure a homogenous mix.

Control of the mix

Material blending is controlled by a level sensor mounted in the upper part of the mix chamber to retain accurate mixing. When the sensor is covered, the blender will not dispense any further batches.

Easy set up

Settings are made easily by either user friendly thumbwheels or entering settings directly on the keypad / optional touchscreen.

Password protection

Special functions can be easily accessed and set via the password protect key.



Audible and visual alarms

An audible and visual alarm sounds should a batch be incomplete.

Reporting

Setup and operation reports can be printed direct to a USB key. Alternatively, data is also available via Ethernet or serial ports allowing remote access and monitoring.

Integration

Integration to other control or ERP systems can be made via leading fieldbus or OPC interfaces.

Quick cleanout

A compressed air gun is provided for quick cleanout.

Rapid color change

Easy access to all material contact surfaces of the machine including hoppers, weigh bin and mixing chamber allows for rapid color changes without the use of tools.

Controller

The Maguire controller monitors and confirms the weight of each ingredient and comes with an optional touchscreen.



WSB 950 Gravimetric Blender Dimensions

Compartment 1 - 3 cu ft [84 Litres]
Compartments 3 & 4 - 1.5 cu ft [42 Litres]
Compartments 2 & 7 - 1 cu ft [28 Litres]

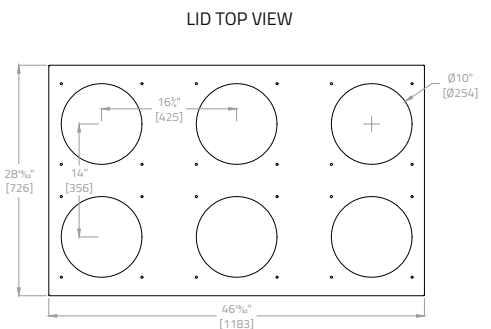
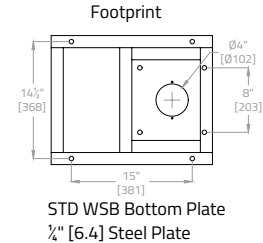
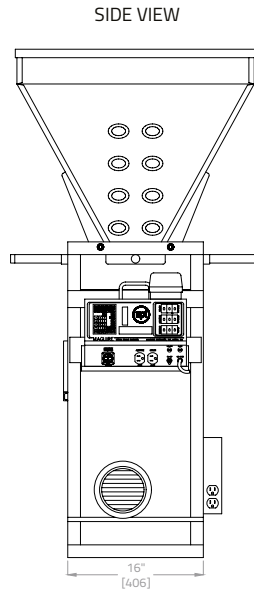
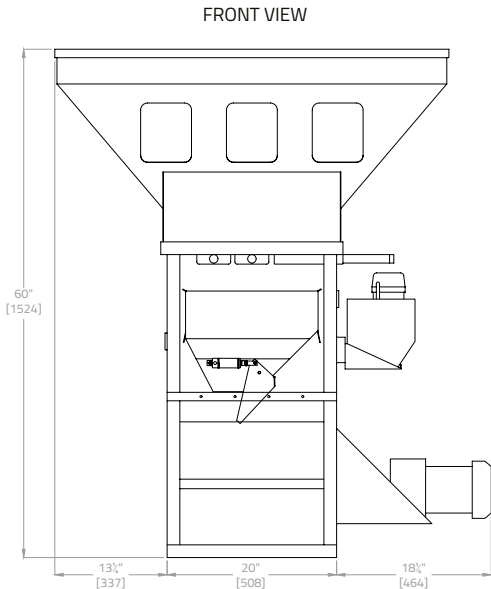

Technical data

Model WSB 950

Maximum Throughput*	970kg/h to 1,200kg/h 2,135lb/h to 2,660lb/h
Number of Materials	5
Material Dispense Systems	1- 3"x6" Slide Gate 4- 2"x3" Slide Gate
Weight	193kg 425lb
Power Supply	120vac - 8.5 Amp 230vac - 2.7 Amp 415vac - 1.1 Amp
Operating Air Pressure	4-6 Bar 60-90psi
Air Consumption	0.3 m³/hr 0.17cfm
Shipping Weight	218Kg 481lb
H x W x D	167 x 140 x 80cm 66 x 55 x 31.5in

*Throughput achieved is influenced by number of materials, how well they flow, vibration and loading consistency - each can effect maximum output of a blender, which in turn effects sizing the correct blender required for an application.

Maguire reserves the right to cancel product or change product, product specifications and data without notice to improve reliability, function, design or otherwise.

Key features

- Ideal for large processing machines
- Reduced weight and footprint
- Overall precision of $\pm 0.1\%$ of specified blend
- Compressed air gun for quick cleanout included
- Easy access to all material contact surfaces of the machine including hoppers, weigh bin, and mixing chamber permits rapid colour change without the use of tools
- Proprietary microprocessor-control technology monitors and confirms the weight of each ingredient / touch-screen optional.
- Compensation is made when a variation in dispense weight is detected
- Vibration Weighing management
- Improved documentation capabilities
- 5 Year Warranty



MAGUIRE WORLDWIDE DISTRIBUTION LOCATIONS

Maguire USA

Aston, PA, USA
T: +1 610 459 4300
F: +1 610 459 2700
E: info@maguire.com

Maguire Canada

Ontario, Canada
T: +1 905 879 1100
F: +1 905 879 1101
E: info@maguirecanada.com

Maguire Europe

Staffordshire, UK
T: +44 1827 338 280
F: +44 1827 338 285
E: info@maguire-europe.com

Maguire IMEA

Dubai, UAE
T: +971 4 881 6700
E: info@maguire-imea.com

Maguire Asia

Singapore
T: +65 6848 7117
F: +65 6542 8577
E: magasia@maguire-products.com.sg

Maguire China

Shanghai
T: +86 21 5882 3410
F: +86 21 5882 3420
E: amber@maguirechina.com