

- VBD-1000:
- design throughput: 1000 lbs./hour
 - maximum temperature: 350°F
 - blower: Cincinnati centrifugal type, VFD controlled, 600 SCFM airflow
 - heater: 25,000 watt resistance coil
 - vacuum sub-system: venturi, 75mm Hg absolute w/ heated membrane purge
 - retention hopper blanketing: membrane dryer through dedicated purge air heater
 - electrical: 480V 3-phase, 60 amp

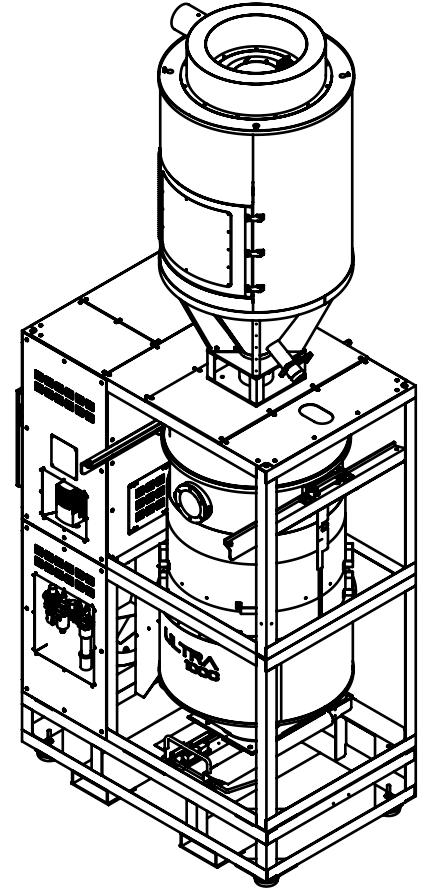

D
C
B
A

D
C
B
A

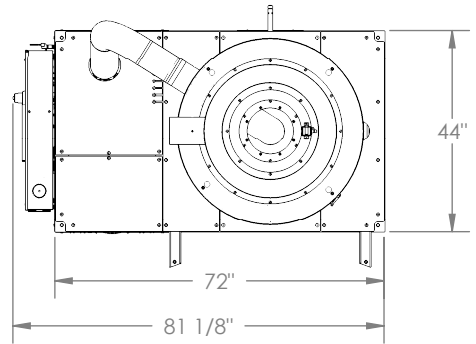
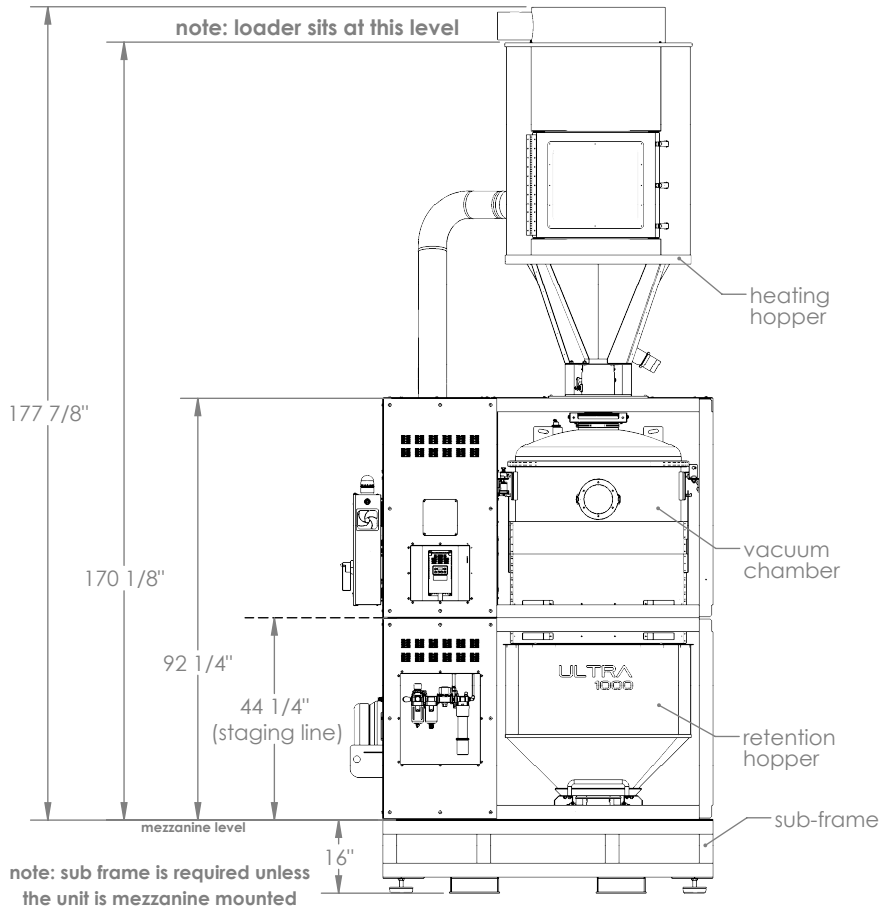

note: sub frame is required unless the unit is mezzanine mounted

UNLESS OTHERWISE SPECIFIED DIMENSIONS ARE IN INCHES TOLERANCES ARE:

FRACTIONS	DECIMALS	ANGLES
±1/64	.XX ± .01 .XXX ± .005	±1°

MAGUIRE

ULTRA-1000
Overall Layout
[USA]

MATERIAL -
PAINT / FINISH -
Drawn By: MG Last Saved By: M. Gera

Created: Wednesday, October 8, 2008 9:48:32 AM
Last Save: Sunday, March 19, 2017 1:39:24 PM
SIZE A DWG. NO. **ULTRA-1000** SHEET 1 OF 2
NAME -
SCALE 1:42

THE INFORMATION CONTAINED IN THIS DRAWING IS THE SOLE PROPERTY OF MAGUIRE PRODUCTS, INC. ANY REPRODUCTION IN PART OR WHOLE WITHOUT THE WRITTEN PERMISSION OF MAGUIRE PRODUCTS, INC. IS PROHIBITED.

REV	ECN	DATE
-	-	-

8

7

6

5

4

3

2

1

8

7

6

5

4

3

2

1

- VBD-1000:
- design throughput: 454 kgs./hour
 - maximum temperature: 176 °C
 - blower: Cincinnati centrifugal type, VFD controlled, 17,000 liters/minute airflow
 - heater: 25,000 watt resistance coil
 - vacuum sub-system: venturi, 75mm Hg absolute w/ heated membrane purge
 - retention hopper blanketing: membrane dryer through dedicated purge air heater
 - electrical: 400V 3-phase, 60 amp

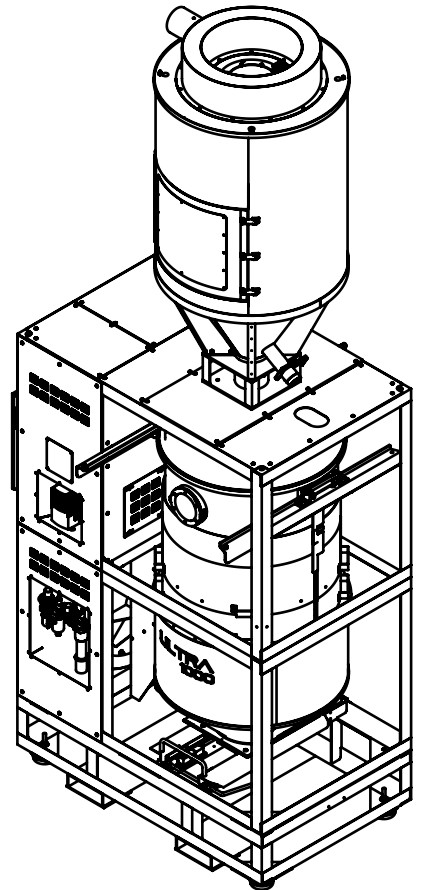
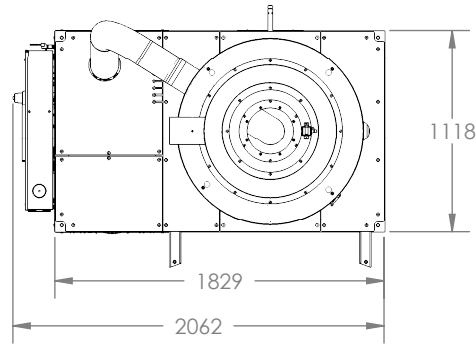

D
C
B
A

D
C
B
A

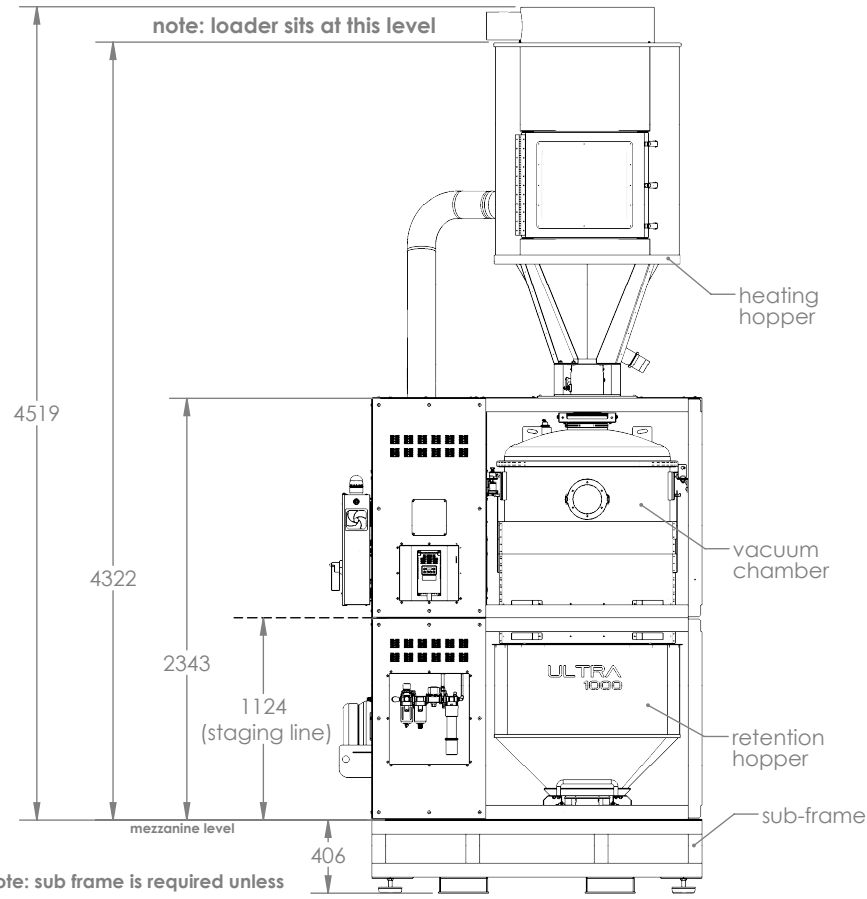

note: sub frame is required unless the unit is mezzanine mounted

UNLESS OTHERWISE SPECIFIED DIMENSIONS ARE IN INCHES TOLERANCES ARE:

FRACTIONS	DECIMALS	ANGLES
±1/64	.XX ± .01 .XXX ± .005	±1°

MATERIAL -
PAINT / FINISH -
Drawn By: MG Last Saved By: M. Gera

MAGUIRE

ULTRA-1000
Overall Layout
[International]

Created: Wednesday, October 8, 2008 9:48:32 AM
Last Save: Sunday, March 19, 2017 1:39:24 PM
SIZE A DWG. NO. **ULTRA-1000** SHEET 2 OF 2
NAME -
SCALE 1:42

THE INFORMATION CONTAINED IN THIS DRAWING IS THE SOLE PROPERTY OF MAGUIRE PRODUCTS, INC. ANY REPRODUCTION IN PART OR WHOLE WITHOUT THE WRITTEN PERMISSION OF MAGUIRE PRODUCTS, INC. IS PROHIBITED.

REV	ECN	DATE
-	-	-

8

7

6

5

4

3

2

1

8

7

6

5

4

3

2

1