

Regrind material preparation – defined grain sizes

- Only consistent regrind in a defined grain size, dedusted and demetallised form, guarantees constant product respectively part quality.
- The different uncontrolled melting processes in the screw, with unequal material sizes will be avoided with our regrind material preparation.

We provide:

- Ready to mount total systems with material handling directly from the granulators or a tank / silo
- Ionizer to reduce electrical charge in the material
- Metal separation of all metals / nonferrous metals
- Material screening unit for the separation of dust, grain-boundary and grain shortfalls
- incl. all necessary container
- incl. piping system and tubing
- incl. electrical wiring

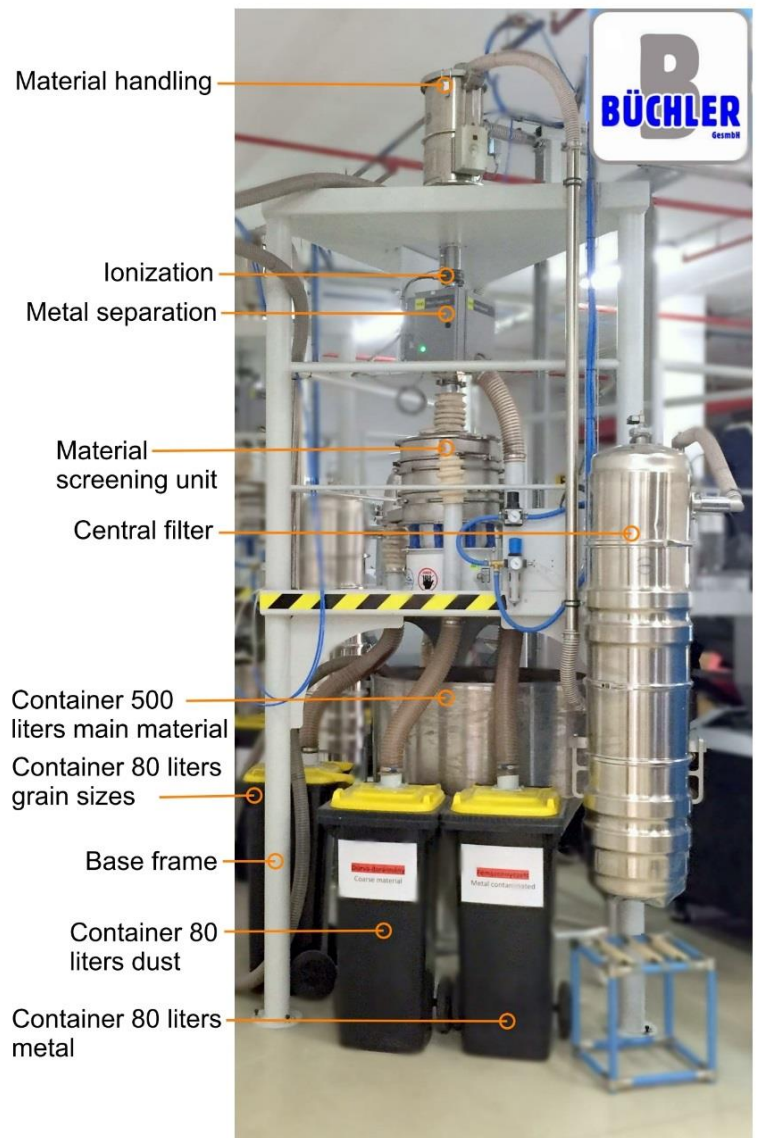

Technical data:

- Space for installation: approx 2,2m²
- Total height: 3.960mm
- Output: 100kg/h
- Screen size: 1mm to 11mm
more screen sizes on request

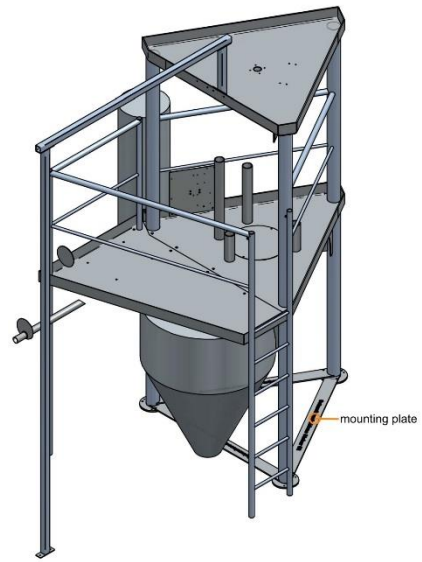

Saving up to 10.000 €/year is possible!

Please fill out the form and send it back to us

Company:	Tel.:
Contact person:	Mobile:
Address:	E-Mail:
City:	Country:
Zip:	
Detailed questions about system dimensioning	
Material throughput [kg/h]:	Material Type:
Bulk density [kg/dm ³]:	Glass Fibre [kg]:
Desired grain size [mm]:	
Other Information:	

